

Staircases

GENERAL STORAGE & FITTING INSTRUCTIONS



CAUTION



PLEASE NOTE:

The weight of some stair parts may dictate special consideration when handling.

Upon delivery of your staircase, please check against the Delivery Ticket to ensure that you have all the required components.

1 Storage of the stairs

Stairs should be stored in a dry place, slightly raised from the ground, adequately protected from the weather and extremes of temperature. As with all internal joinery, stairs should not be fitted in a building which has not adequately dried out. Failure to maintain the moisture content as delivered will have a seriously detrimental effect on the stairs and how they fit.

2 Fitting of a staircase

A plan of the staircase is included and the usual procedure is to start from the top of the stair and work downwards. Dimensions are taken from the back of the riser with a fitting tolerance of between 10-25mm, it is therefore necessary to notch the string and/or newel post over the trimmer. See figure 1.

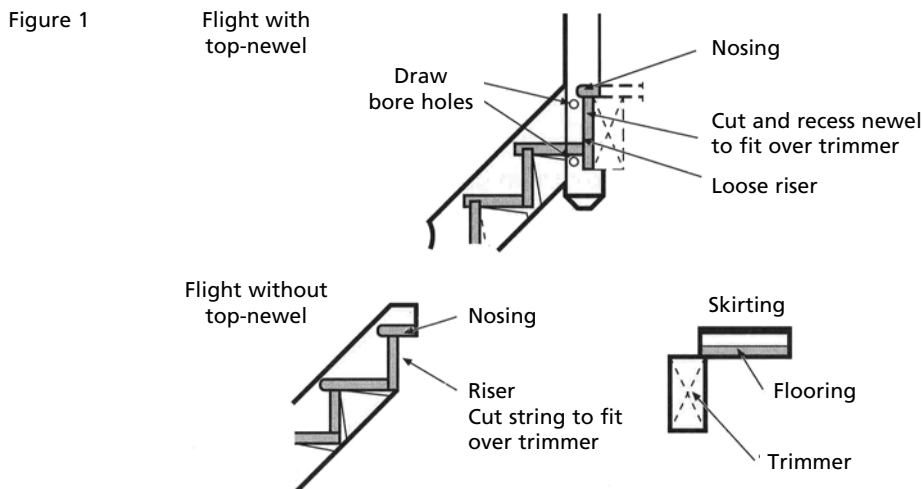

Unless otherwise requested, newel post(s) / strings and loose risers provided will require cutting to suit finished floor level in situ. In all other respects the stairs will have been made to an agreed finished floor to finished floor rise.

We recommend newel posts be fitted 'dry' and the stair offered into position. Check level of treads and plumb of newel posts, increased moisture content may affect this.

3 Always ensure the newel is plumb

The newel post will have been drilled for 10mm dowel supplied. When newel posts are plumb, mark position and drill through string/tenon. (If you drill off centre approx. 1-2mm towards the shoulder, this will have the effect of pulling the newel onto the string).

Glue and dowel the newel into position ensuring it is tight to the shoulder. See figure 2.

Locate loose riser into groove of nosing, trim to length around newel post, pin and glue riser to string and newel post when fitting flat against trimmer, glue and screw riser to tread.

When a bullnose is supplied, fix the newel (if applicable), check the length and fit of the bullnose. Wedge and glue tread into string, blue and pin riser into newel post. Locate loose riser into tread groove, glue and pin into newel post and glue and wedge into the string, glue and screw riser to tread.

If fitting winder treads, again 'dry' assemble. Treads have been cut to size in our workshop but may need further trimming when installed. Check treads for level and fit. Risers will need to be cut to length and bevelled to fit angles. Treads and risers should be wedged and glued into the string and pinned and blocked at newel posts where the riser meets the tread, always screw and glue into position to prevent 'squeaking'. Bearers should be fitted to underside of risers at winders, in accordance with BS 585. See figure 3 (overleaf).

Strings running against a wall should be securely fixed at approx, every 600mm and packed to prevent the fixings pulling the string off the treads and risers.

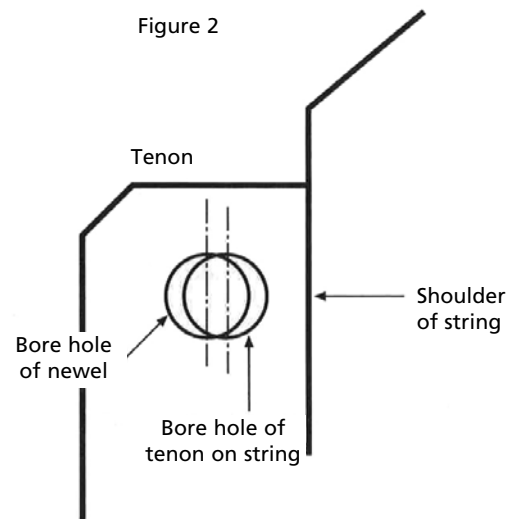

4 Fixing the risers to the treads

Glue and pin blocks to underside of treads and risers where riser fits onto groove, as on main lifts.

Always screw the glue risers to the treads.

Figure 3

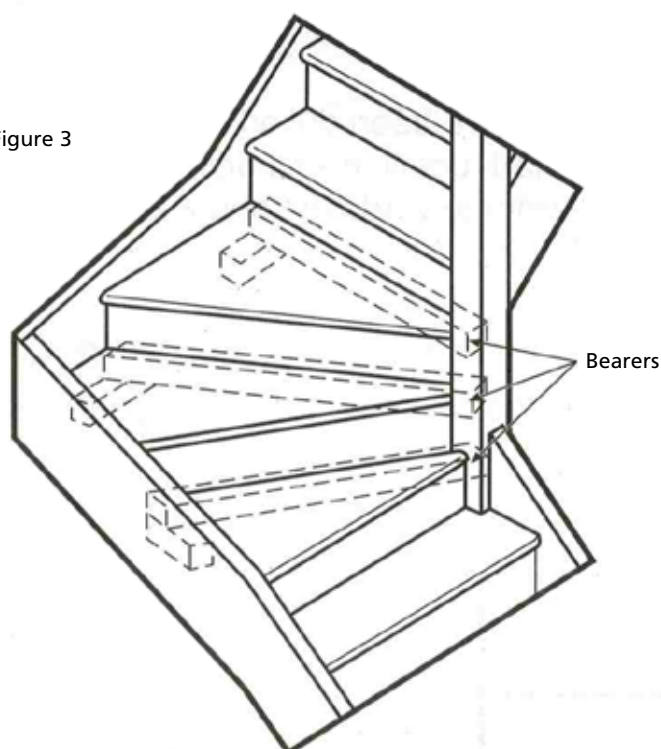

All staircases are guaranteed for ten years against manufacturing defects.