

selkie  
stone



Earthstone

## EASY TO INSTALL LUXURY ALTERNATIVE TO TILES

As a waterproof product, Selkie Stone™ 6mm cast sheets do not require additional support and are easily fixed to almost every surface. The panels can be fitted directly onto brick, block, plaster and even tiled walls providing the surface is sound, dry and free from dust and grease and a suitable adhesive is used.

### Recommended Tools

- circular saw,  
a 40 / 60 tooth carbide blade recommended
- router
- jigsaw, a fine tooth blade, downward cut if possible
- power planer
- drill
- silicone gun
- Selkie Silicone Sealant
- Selkie 'Grip All' Adhesive
- spirit level



For bonding to existing walls we recommend a moisture cure, solvent-free adhesive such as 'Selkie Grip All' and for corner and edge joints we recommend a silicone sealant such as 'Selkie Sealant' or similar.



Rearo  
Unit 15 & 16 Primrose Lane  
Dunfermline Business Park  
Rosyth  
Fife  
KY11 2RN

Tel - 01383 414000  
Fax - 01383 414400  
E-Mail - rosyth@rearo.co.uk

Rearo  
Unit 3  
Eastern Avenue Trade Park  
Team Valley  
Gateshead  
NE11 0PG

Tel - 0191 4822298  
Fax - 0191 4826245  
E-Mail - gateshead@rearo.co.uk

Rearo  
Staneyhill Gas Depot  
North Road  
Lerwick  
Shetland Isles  
ZE1 0QA

Tel - 01595 692807  
Fax - 01595 695469  
E-Mail - lerwick@rearo.co.uk

Rearo  
Unit 14 & 15 Estuary Court  
Estuary Road, Queensway Meadows  
Newport  
Gwent  
NP19 4SP

Tel - 01633 283000  
Fax - 01633 283001  
E-Mail - newport@rearo.co.uk

Rearo  
7 Burnett Road  
Longman Industrial Estate  
Inverness  
IV1 1TF

Tel - 01463 239918  
Fax - 01463 221130  
E-Mail - inverness@rearo.co.uk

Rearo, Loanbank House, Loanbank Quadrant, Govan, Glasgow, G51 3HZ  
Tel: 0141 440 0800 Fax: 0141 445 3342 www.rearo.co.uk sales@rearo.co.uk



AN EASY TO INSTALL LUXURY ALTERNATIVE TO TILES



selkie  
**stone**

INSTALLATION INSTRUCTIONS



### Site condition and preparation

Selkie Stone™ wall panels should always be handled with care and stored flat.

Check to ensure that all panels are evenly coloured and from the same batch.

Before installation the panels should be left to settle to room temperature of a min. 17°C (62°F). Panel products and jointing strips will become more brittle in cold temperatures. Ambient temperatures below 17°C will also prolong the drying time of the adhesive.

Ensure that all walls are flat and even, i.e. free from excessive hollows or protruding bumps. Painted or tiled surfaces should be suitably 'keyed' before applying adhesive.

Please note: due to the makeup of the Wheat Elegance panel, walls should be prepared to an even colour prior to fitting.

### Handling Selkie Stone™ panels

Selkie Stone™ panels have a finished surface, so care should be taken when opening packaging, no sharp instruments should be used.

Panels should not be carried flat (that is, face up or down). It is recommended that panels are carried on their side and care should be taken as any excessive sagging in the middle of the boards could cause breakage.

Panels should never be rested on a corner as chipping could occur.

It is recommended, in most situations, to have two people to assist in both the handling and, due to the nature of most domestic bathroom situations, the completion of the final "fit".

### Cutting Panels

Cut panels to size using a circular saw, router or jigsaw - use masking tape to ensure a clean cut. Allow for 3mm expansion gap for each panel

Panels must be supported along the full length of the panel when cutting on both sides of the cut being made.

Determine that all holes and cut-outs have been located correctly and machined to the correct dimensions i.e. 3mm oversize (all round) to allow for expansion and contraction.

If cutting apertures for valves or fittings ensure that an internal 8mm radius is provided.

We recommend that before each panel is bonded in place they are 'dry' fitted to make sure that they have been correctly measured for size and fit.

It is recommended that Selkie Stone™ panels are fitted on top of a shower tray or bath.

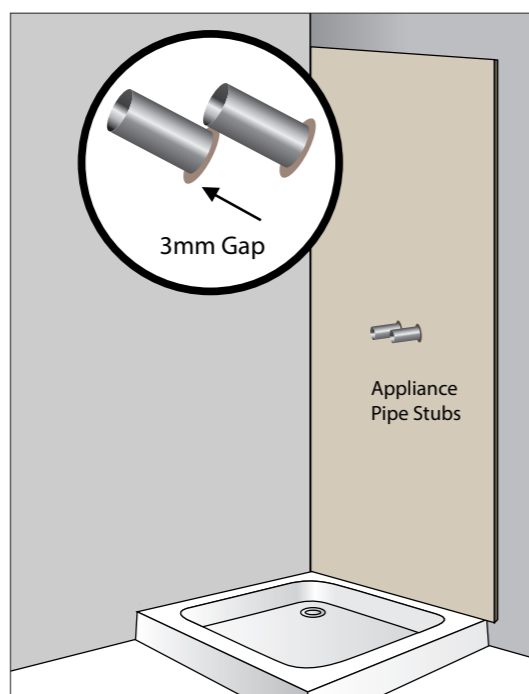
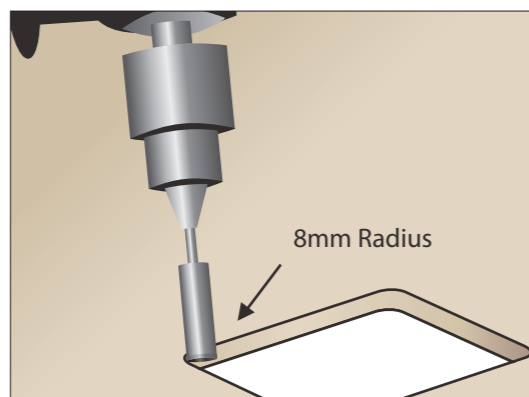
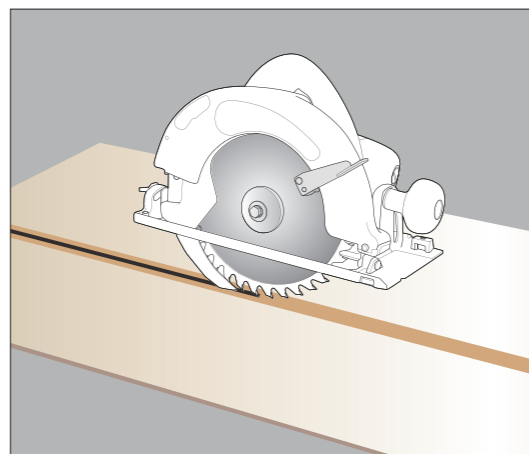
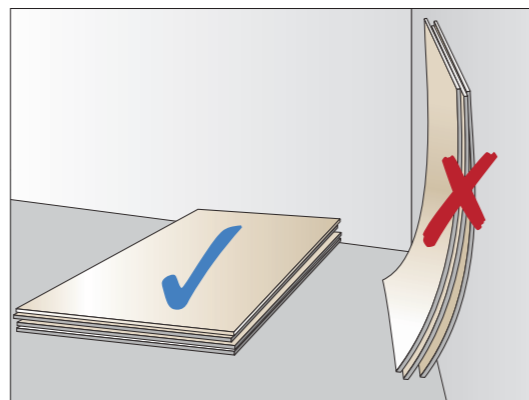
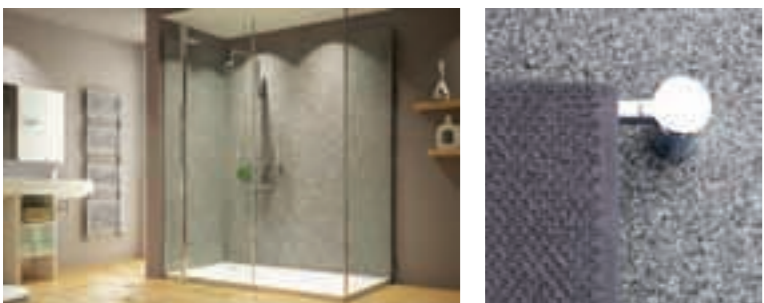

### Site and installation considerations

Do not mount load-bearing accessories, e.g. grab handles, directly on to Surfstone™ panels. Ensure that any load-bearing item is mounted through the panel, securely fixed into the wall and sealed with silicone. Remember to make your cutting or drill hole 3mm bigger to allow for possible expansion.

Care should be taken when drilling close to the edge of a panel in particular when attaching shower enclosure and doors. Panels should be adequately supported.

**Note: drill hole should be larger than diameter of screw and fixing should be made through panel into the wall. The fixing should not be over tightened.**

### Installation sequence

Ensure the wall and the back of the bathroom panels are free from dust, clean and dry. If necessary wipe off with damp cloth and allow to fully dry before proceeding.

Apply 6mm bead of adhesive such as Selkie 'Grip All' as evenly as possible to the panel 12mm from edge of the panel and at approximately 300mm intervals vertically across the reverse side.

Press panel firmly into place and apply even pressure across the whole panel to achieve a flat surface. Uneven pressure may result in wavy appearance of the panel. A solid straight-edge (4' x 2" timber or similar) can be used to gently press the panel into place until correctly aligned.

Always ensure that panel 1 is secure and in correct position before installing panel 2 and subsequent panels.

For internal corner panels, leave a gap of 2mm between the wall and the edge of the panel to allow for expansion. Similarly, leave a 2mm gap for the adjoining panel. A gap between panels for a joint strip should be approx. 6mm

### Panelling over existing tiles:

When fixing the panels over existing tiling, we would recommend the following procedure:

- ensure that the existing tiles are securely fixed to the wall
- check that the extra thickness of panelling does not interfere with the operation of existing features such as taps, shower mixer valves, doors and architraves
- always 'key' the surface of the tiles
- the surface of the tiles must be free of grease and dust.

### Shower Tray / Bath Seal

It is **IMPORTANT** that the Selkie Stone panel does not rest on the top of the bath or shower tray - instead the panel should be secured to the vertical wall while leaving a clear gap of approximately 2mm.

Then ensuring that all edges are free of dust, carefully apply a bead of Selkie Silicone sealant along the length of the 2mm gap between Selkie Stone panel and the bath / shower tray. If required, run a wet finger along the seal to ensure a smooth finish.

Please note that for Selkie Stone™ WE DO NOT recommend the use of 'Panseal'.

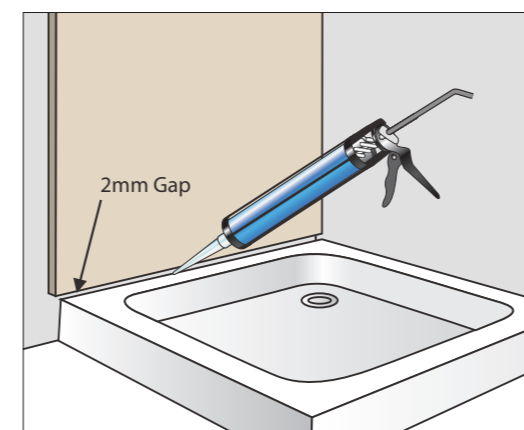
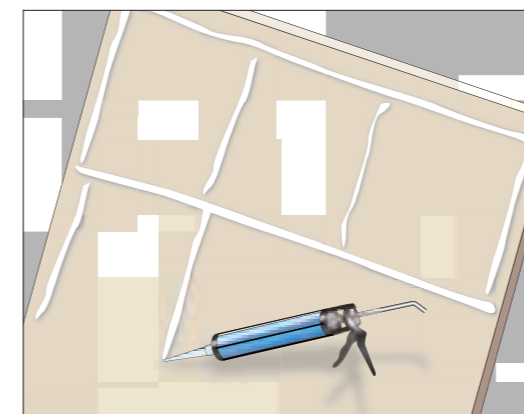
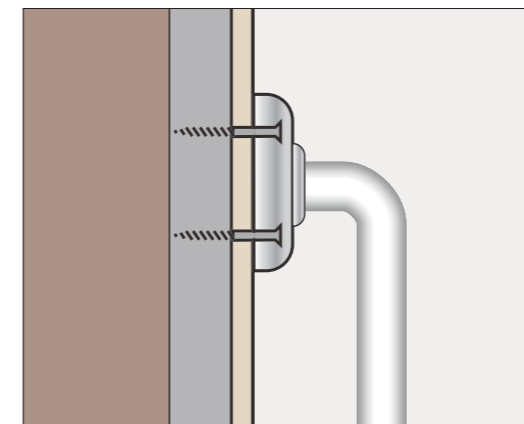

### Tradesman's tip for a perfect fit:

To ensure a secure and square installation follow this handy tip when installing Selkie Stone panels in sequence.

- apply 'Selkie Grip All' adhesive or similar to the back of panel one and position in place on wall. It can be helpful (before the adhesive sets) to help secure panel in position with the aid of strong masking tape
- leaving a 5/6mm gap, repeat application of adhesive and position panel 2 and again support with masking tape to help secure (if required).
- using 4 evenly spaced 'modesty' blocks (or make up 4 small strips of wood drilled with a centred hole). Secure each one to the centre of the 5/6mm gap, with gentle pressure to bring both panels into alignment
- once panel adhesive has 'bonded' - remove fittings and with new evenly installed panels proceed to a perfect installation of the joining profile.

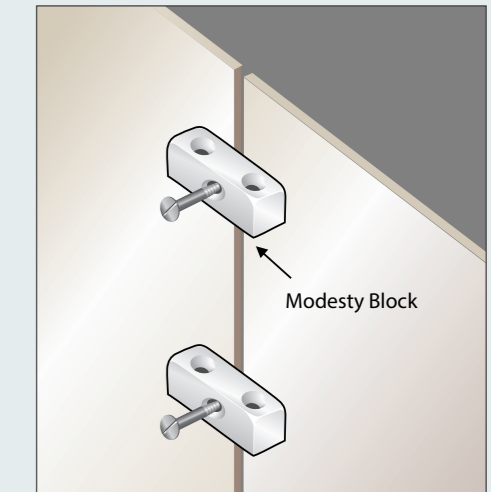

### Jointing Profiles

**Note: Jointing profiles should only be unpacked and fitted immediately prior to fitting.**

To finish a 90° angle installation, insert a Selkie Stone™ "corner" jointing profile. Use one small bead of clear Selkie silicone directly in the corner of the panels to seal the joint and to adhere to the corner profile. Both internal and external corner jointing profiles are available.

When using two (or more) Selkie Stone™ panels in sequence, insert a standard jointing strip into the 5/6mm gap between panels using clear silicone. Hold panel in place, if necessary, using masking tape or similar.

Remove any excess silicone which may have been squeezed out onto the surface of the panels during the application of the beading process.

### Surface finish

After installation, simply wipe the surface with a damp cloth until all the dust is removed and then buff the surface with a clean dry cloth.

### Care and Maintenance

General care in preserving the beauty and functionality of Selkie Stone™ is as simple as wiping with a warm damp cloth. Light scratches can be repaired. Please contact your local agent for further advice.

### Product warranty

Selkie Stone™ products are warranted under a manufacturer's warranty to be free from material defects in workmanship or materials for a period of 10 years from the time of collection or delivery.

Selkie Stone™ will undertake to make good by repair or replacement, in full or in part, any products which can be shown to have failed by reason of defects in manufacture, that is subject to fair wear and tear, which is hereby excluded. Full details of warranty terms and conditions are available upon request.

Proof and date of purchase must accompany any claim under this warranty.

