

MEDITE® TRICOYA®



# CLADDING BOARD AND PANEL APPLICATIONS

P&M GRIMES &

# CONTENTS

About the panel	3
Features and benefits	4
Properties	6
Boarding	8
horizontal	8
vertical/diagonal	9
grooved panels	10
ventilation and joints	10
fasteners and placing	11
fixing distance	11
Panel cladding	12
screw fixing	12
fixing distances	14
corner details	15
ventilation and joints	16
Other exterior applications	17
Coatings	18
More information	20

# MEDITE TRICOYA

These guidelines have been written for professionals wishing to use Medite® Tricoya® to create beautiful, reliable and highly durable end products.

This document was developed in close cooperation with Alexis Harrison and Stephen Philips of ARUP.

## Stephen Philips

Industrial designer with experience in the design of high performance building products and projects.

## Alexis Harrison

Designer and materials specialist with experience of building and cladding system design with specialist knowledge of architectural practices.

Should you require further information or have any comments about this document, please contact Medite through [www.meditetricoya.com](http://www.meditetricoya.com).

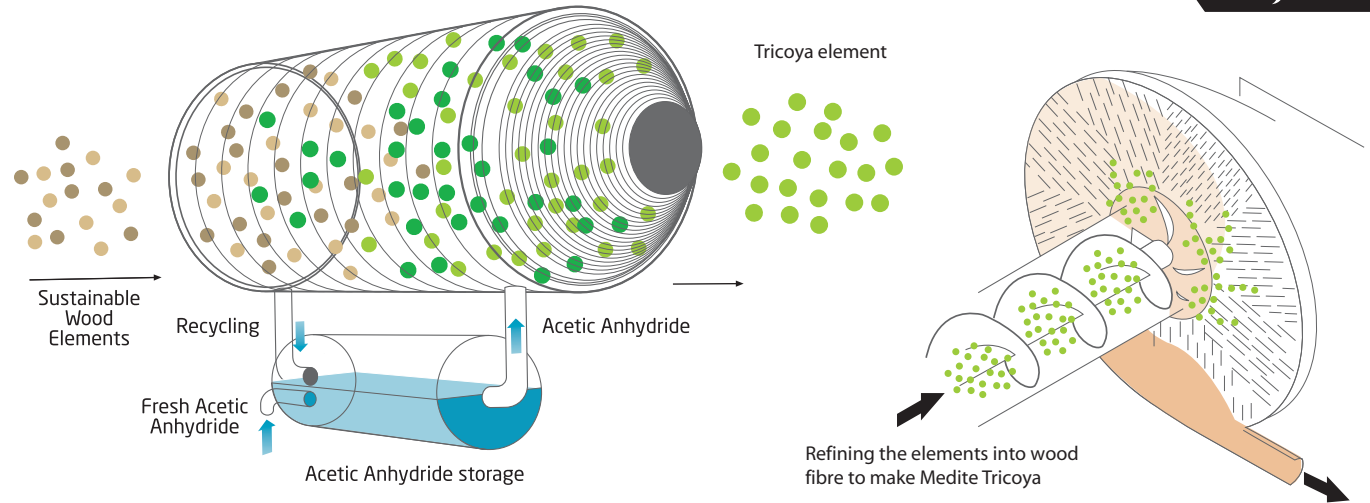

© Image copyright to Medite

## ABOUT THE PANEL

Medite Tricoya is a completely new, innovative form of panel product. It demonstrates outstanding durability and stability in the most extreme and challenging environments - both exterior as well as interior wet applications. The product uses proprietary acetylation wood technology and a modified fibre board manufacturing process to create a wood panel product with outstanding durability and stability.

Medite Tricoya was developed by challenging the most fundamental reason for wood swelling and decay: water adsorption onto hygroscopic wood fibres due to the presence of hydroxyl groups. The hydroxyl groups (water loving sites) can bind or release water molecules causing wood to swell or shrink.

Acetylation is a non-toxic, sustainable process which increases the number of naturally occurring hydrophobic acetyl groups in the wood cells using acetic anhydride. The process exchanges the hydroxyl groups (chemical formula: -OH) with acetyl groups (chemical formula: -COCH<sub>3</sub>) preventing water adsorption at these sites, and thus enhancing the dimensional stability and durability of the wood.

Apart from creating an exceptional dimensional stability, the process enables Medite Tricoya to achieve Class 1 Durability, leading to resistance to biological decay which exceeds oak.

Medite Tricoya offers a solution for specifiers and consumers in environments of wet, high humidity or fully weather exposed applications to deliver superior performance in versatile large panel form.



# FEATURES & BENEFITS



## DURABLE

Longer lasting, perfect for external and internal wet environments



## 50 YEAR GUARANTEE

Peace of mind with a 25 year in-ground and 50 year above ground Medite Tricoya guarantee



## ENHANCED STABILITY

Swelling and shrinking dramatically reduced



## DESIGN FREEDOM

All the design, fixing and machining flexibility of medium density fibreboards



## LOWER MAINTENANCE COST

Extended periods between exterior coatings maintenance



## PERFECT FOR COATING

Improved stability and durability enhances service life of the coating. Damaged coating will not affect core durability.



## RESISTANT TO FUNGAL DECAY

Effective barrier to fungal decay



## SUSTAINABLY SOURCED

FSC certified. Wood used from sustainable sources



## DESIRED SERVICE LIFE OF 60 YEARS

Independent testing by BRE shows an expected service life of 60 years for exterior use

# PROPERTIES

Medite Tricoya is a new class of durable wood panel product with enhanced dimensionally stability, suitable for a wide range of exterior applications such as cladding, façade panelling, fascias, soffits, etc. Medite Tricoya can be cut, machined and installed using techniques and equipment commonly used throughout the building industry and require very low maintenance thereafter. The flexibility of Medite Tricoya offers endless design opportunities so that it can be cut to size, machined, painted, wrapped etc. without impacting on its unique properties.

## MOISTURE CONTENT

Medite Tricoya is supplied with a moisture content of between 3% - 5%. The moisture content of panels at the time of installation should be as close as possible to the inservice moisture content. If a measurement shows a moisture content of 8% or more this may indicate the presence of "free water" and the Medite Tricoya should be allowed to dry before processing, gluing or coating.

## CE MARKING

All Medite MDF products supplied for use in the construction and civil engineering industries are CE marked according to the requirements of the harmonized European standard for wood based panels EN 13986. This provides the necessary assurance to customers and users that Medite Tricoya conforms to the European MDF standard, EN622-5 and meets all the essential requirements for the Construction Products Regulation (CPR) that are relevant to the product.

## REPORTS AND CERTIFICATES

The Fraunhofer Institute for Wood Research (WKI), conclude that the performance of Medite Tricoya is so outstanding that it will allow an MDF type panel board to be used in applications that have not previously been possible.

Building Research Establishment (BRE) performance testing indicates that Medite Tricoya achieves durability class 1 under EN350-2. Durability is equivalent to teak and more durable than oak.

SP Wood Technology tested the product's ability to resist wood destroying basidiomycetes (white and brown rot).

British Board of Agrément (BBA) assessment concludes that Medite Tricoya is suitable for internal and external non-structural applications (BBA Assessment number M2/49109).

For copies of these reports and/or certificates, please contact our sales office or visit our website.



PHYSICAL PROPERTIES	RANGE	TEST METHOD	UNITS	VALUE
Density	+/-30	EN 323	kg/m <sup>3</sup>	720 (9, 12 mm) 700 (15, 18 mm)
Dimensional Stability				
Coefficient of thermal expansion		NPL	mm/m °C	0.0137
Per 10% RH change		NPL	mm/m	0.25
Thermal Conductivity		EN 12664	W/m K	0.095
DIMENSIONS				
Width	± 1 mm/m	EN 324-1	mm	1220
Length	± 1 mm/m	EN 324-1	mm	2440
Thickness	± 0.15	EN 324-1	mm	9, 12, 15, 18
MECHANICAL PROPERTIES				
E-modulus		EN 310	N/mm <sup>2</sup>	≥ 3000 (9 mm) ≥ 2500 (12, 15, 18 mm)
Bending Strength		EN 310	N/mm <sup>2</sup>	≥ 30 (9 mm) ≥ 25 (12 mm) ≥ 20 (15, 18 mm)
Tensile Strength		EN 319	N/mm <sup>2</sup>	> 0.8

THE RESULTS LISTED ABOVE ARE BASED ON THE MINIMUM SPECIFICATION REQUIREMENTS FOR MEDITE TRICOYA MANUFACTURED BY MEDITE EUROPE LTD. ALL PARAMETERS ARE IN COMPLIANCE WITH EN 622 PARTS 1 & 5. AS PART OF THE MEDITE EUROPE ONGOING PRODUCT DEVELOPMENT PROGRAMME, THE RIGHT TO MODIFY THESE PRODUCT SPECIFICATIONS WITHOUT NOTICE IS RESERVED. MEDITE TRICOYA CONTAINS NO ADDED FORMALDEHYDE AND THE FORMALDEHYDE CONTENT IS LESS THAN 1.0 MG/100 G USING EN 120 TEST METHOD, WHICH IS FAR BELOW THE LOWER LEVELS REQUIRED BY CARB PHASE 2.

# BOARDING

If using the Medite Tricoya board in a system which resembles a wooden cladding system there are a number of jointing techniques as with regular cladding which can be considered depending on the final appearance of the façade.

Traditionally normal wood type cladding measures 150 mm wide, with a recommended limit of 190 mm due to cupping issues. The width of Medite Tricoya boards is not restricted by cupping and can therefore be wider, leading to a strong visual appeal unobtainable with traditional wood.

Medite Tricoya is suitable for standard cladding types, and in general, the installer should follow the same recommendations for fitting as with traditional wood boarding, requiring no special detailing or tools. As with traditional wood boarding, a ventilated cavity needs to be present behind the boards.

Medite Tricoya panels can be cut, profiled, embossed or routed to specified designs without encountering restrictions or issues associated with the instability of traditional cladding products while maintaining its durability.

The most popular designs are:

- Open jointed
- Square edge
- Shiplap
- Tongue and Groove

Other designs are of course possible.

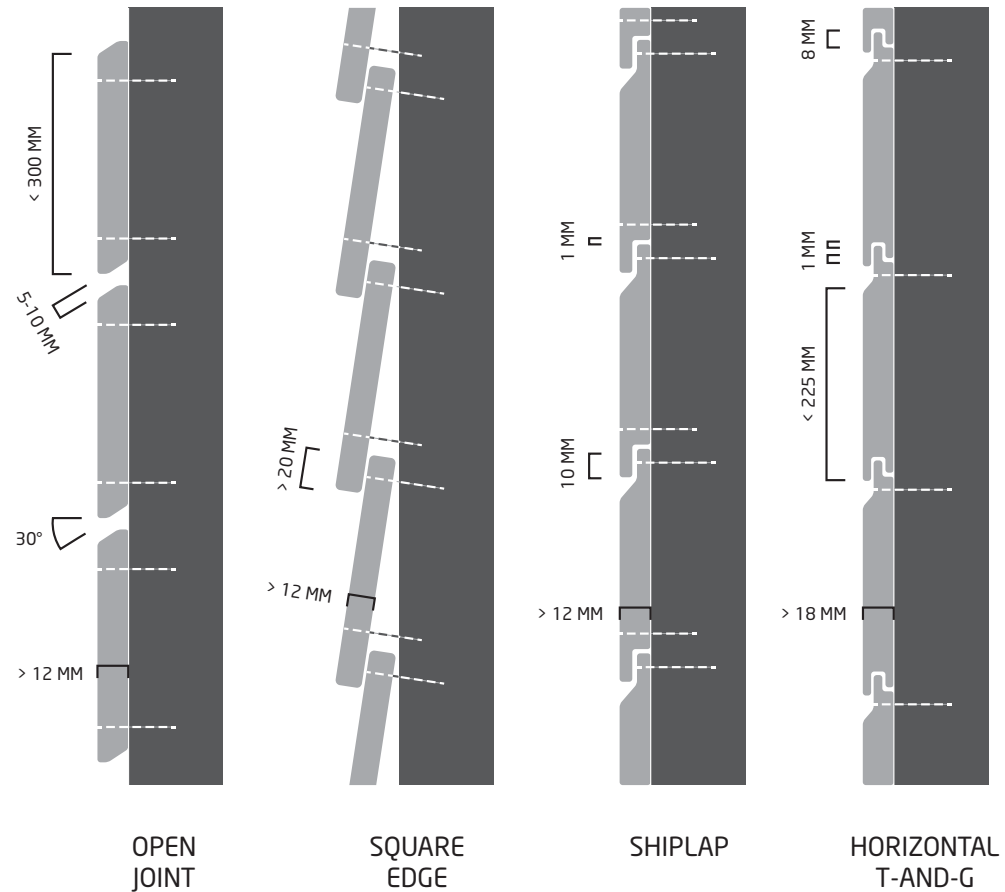

## Horizontal boarding

When mounted horizontally, the fixing can be made invisible.

### <300 MM FACE WIDTH

For horizontal boarding not exceeding 300 mm face width, the open joint chamfered boards should have a 5 - 10 mm gap between the boards at the outer face. The vertical overlaps of square and feather edge should be at least 20 mm.

When choosing a shiplap profile, the minimum vertical overlap can be reduced to 10 mm, but there should be at least a 1 mm gap between rebate and board / up stand below (see also the section on joints on page 10).

### <225 MM FACE WIDTH

Horizontal tongue and grooved boards should not exceed 225 mm face width. The depth of the tongue should be at least 10 mm, with at least a 1 mm gap between tongue and groove shoulders. The boards should always be installed with the tongue upwards, to prevent water penetrating the profile.



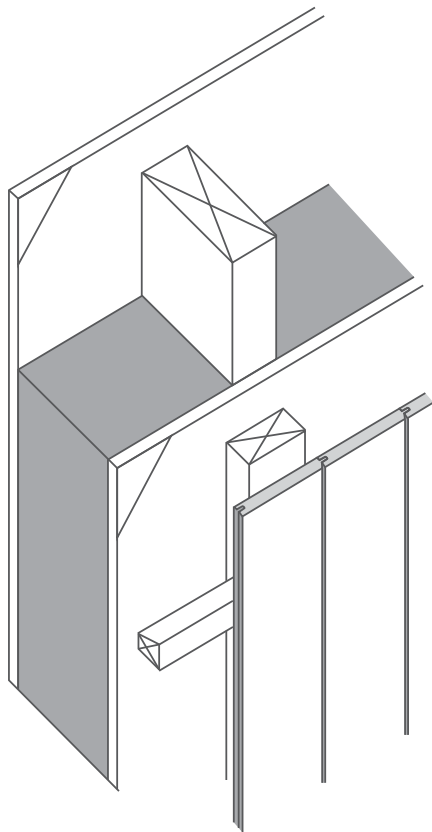

### Vertical and diagonal boarding

The board designs suitable for vertical boarding are (overlapping) square edge, shiplap and tongue and groove.

When installing the profiles vertically at least two fasteners per board are necessary and at least one of these fasteners, such as a nail will be visible. It is recommended to limit the board lengths to the storey height, and end joints must relate to batten positions.

A double sub frame is best practice where horizontal fixing battens are fastened on vertical counter battens (see figure opposite). The horizontal battens should be chamfered at the top side, shedding water into the cavity. The lowest batten should slant inward at the bottom, creating a drip lip at the intersection with the counter battens.

If only horizontal (fixing) battens are used, additional measures need to be taken to ensure sufficient ventilation. For example, making cut-outs in the battens or interrupting the battens at regular intervals and staggered relative to each other. In this case it is preferable if the horizontal battens are chamfered on the top edge to shed any water outwards.

Water penetration at the end grain of vertical battens should be avoided by applying a sealer.

### <225 MM FACE WIDTH

For vertical boarding not exceeding 225 mm face width, the overlap distance for board on board fixing should be at least 15 mm. Board widths can vary between the inner and outer layer, but fixings through the outer boards should never pass through the board behind, to avoid splitting.

It is also possible to use an open joint, with a 5 - 10 mm gap between boards. The edge sides of the boards should be slanted outward, with a gap of at least 5 mm between board ends. Note that by leaving the joints open, the cavity and the sub-frame is visible, and a UV-resistant breather membrane must therefore be applied.

### <175 MM FACE WIDTH

The face width of the shiplap profile should be limited to 175 mm (15 mm thickness), while the face width of the tongue and groove profiled boards should not exceed 150 mm (18 mm thickness). The groove should be at least 10 mm deep, with a 1 mm gap between tongue and groove and shoulders.

## Grooved panels

Full panel utilisation width and length can be used and may include design requirements such as routing into the surface to create the impression of traditional joint types or novel artistic design.

Please note that when fixing this type of panel to the sub-frame, it is recommended using a fixing system suitable for panels (see the chapter on panel cladding; from page 12). In any case, the pull-out strength of the total fixing system of the grooved panel should be checked by an engineer.

## Ventilation

To ensure that rain water and condensation behind the boarding is removed and the insulation behind the panels will not lose its effectiveness, a continuously ventilated cavity should be present behind the outer decorative layer. This cavity is ventilated through the ventilation in- and outlets situated at the top and bottom of the façade (at least 200 mm<sup>2</sup> per m<sup>2</sup> cladding). It is recommended that the depth of the cavity behind the cladding should be at least 20 mm.

Note that the cavity depth as well as the minimum size of the ventilation in- and outlets must be in accordance with applicable building standards and regulations and that a water repellent, breathable membrane (UV resistant when joints are left open) is applied at the back of the cavity. An insect mesh might be required in ventilation in- and outlets and/or in case of open joints.

Although not a technical requirement for Medite Tricoya, it is recommended for aesthetic reasons that cladding boards are positioned on the façade in such a way that no direct contact with the soil can take place. Furthermore, mounting the boards in the splash zone, between ground level and a height of 200 to 250 mm, will lead to a reduction in service life of any coating (in case of a paved surface). Applying a gravel section below the cladding is recommended.

## Joints

Medite Tricoya cladding boards need to be installed with a mutual distance of at least 1 mm. When meeting other construction elements and/or between the lengths of two boards, a free space of 5 mm should be allowed for.

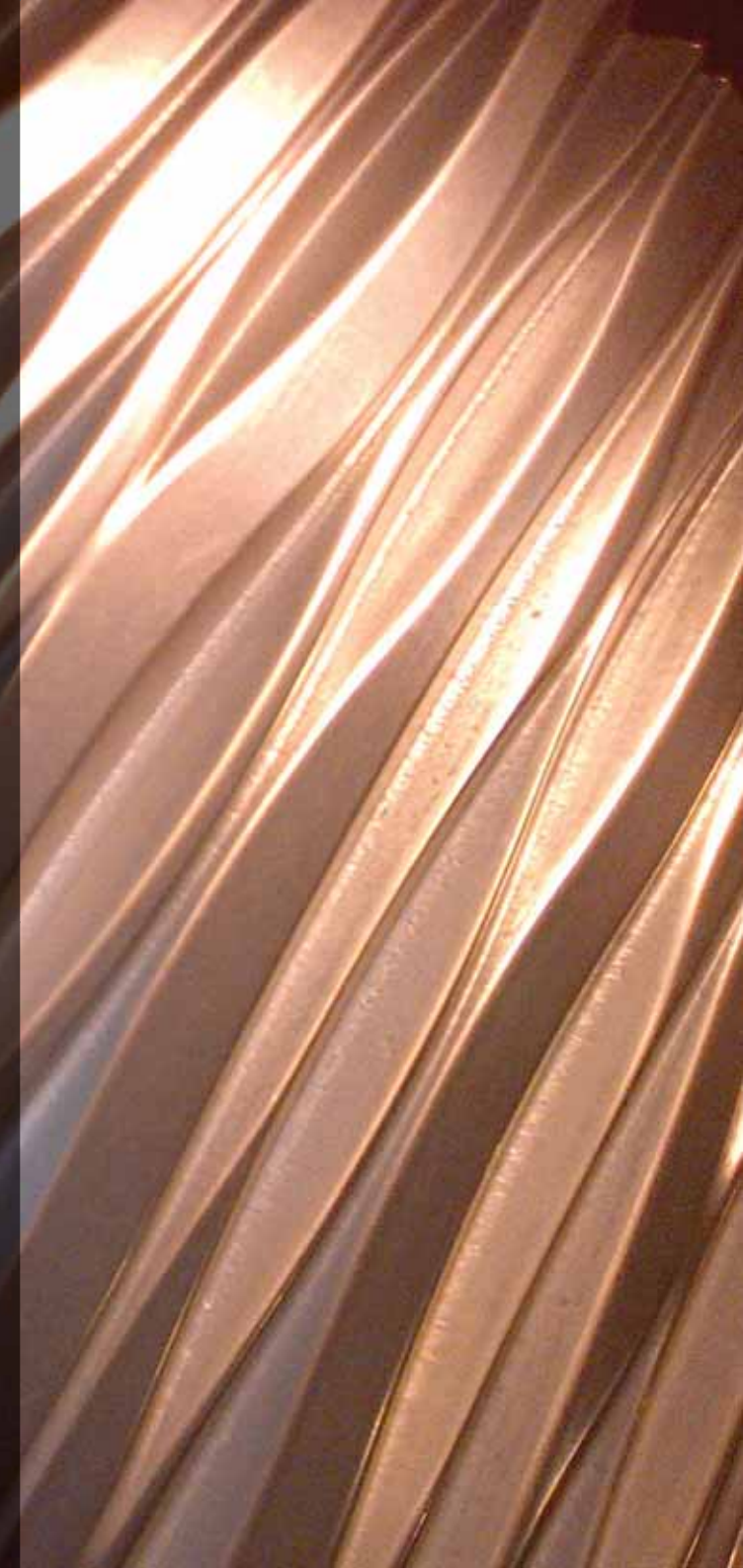

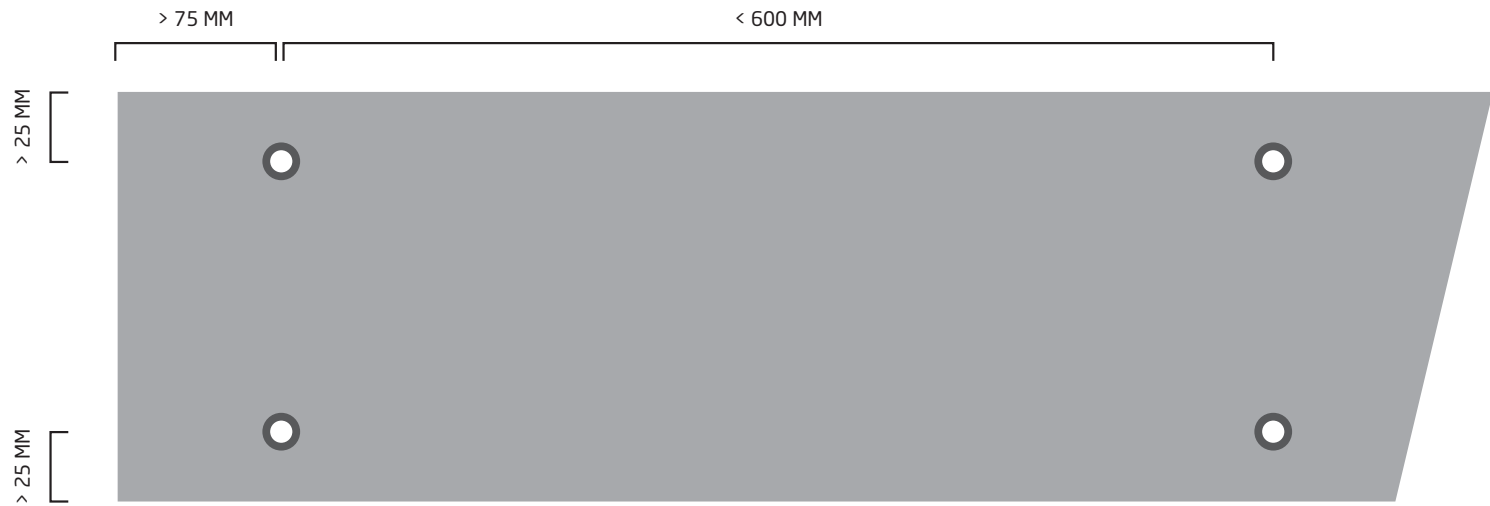

### Fasteners and placing

Medite Tricoya can be face fixed (and in some cases secret) onto the wooden sub-frame with ring shank (or other improved) nails or screws (raised head or round head), made of stainless steel type A2 or A4.

Stapling is not recommended, nor is it to drive the nail or screw heads into the wood. T-nails should not be used for external cladding as they offer little resistance to axial withdrawal. Lost head nails should also be avoided as they offer little resistance to pull-through.

When using screws, it is recommended to pre drill the holes in the Medite Tricoya with a diameter which is 1 mm smaller than the screw shank. Nail holes should be predrilled to 80% of the diameter.

The recommended point side penetration of nails into the timber battens is:

- Smooth nails: 12d\*
- Ring shank and other improved mails: 6d  
(grooved panels: at least 10 d)

\*d = shank diameter of the fastener

If the nail head is at least 2d it is assumed pull-through will not occur, because the pull-through resistance exceeds the withdrawal resistance. As a general rule, the length of a standard nail (and therefore also the minimum sub-frame thickness) will be approximately 2,5 x board thickness and with ring-shank and other improved nails standard nails approximately 2 x board thickness.

Screws have a greater axial strength than nails, and are therefore recommended for use with grooved panels. There are as yet no general guidelines on withdrawal capacity for the most common dowel type fasteners like screws used with standard timber cladding.

To ensure a durable and lasting fixation, the boards should be fixed with at least 75 mm clearance to the end of the board (pre drill hole to 1 mm less than the shank diameter or 80% of nail diameter). The minimum distance to the top and bottom edge of the boards is 25 mm.

### Fixing distance

Support battens should not exceed 600 mm spacing, whether vertical or horizontal, to limit the span of the cladding board. For diagonal boards the spacing of the support battens should not exceed 400 mm, unless the battens are installed diagonally also.



# PANEL CLADDING

When considering a rain screen system with panel style cladding, there are certain issues that need to be considered, among which the fixings used to make up the system. The fixing methods to consider for Medite Tricoya include adhesive and screw fixings.

Please be advised that all recommendations in this brochure are guidelines, and should be checked by the proper authorities on conformity with local circumstances, building codes and standards and checked by a licensed engineer.

Please take note of the guidelines on possible fixing systems, ventilation, sub frames, joints and fasteners described in this brochure when designing cladding with Medite Tricoya, and ensure that the recommended fixing positions and fasteners are used. Contact our sales office for further support on possible fixing systems.

For façade cladding with Medite Tricoya, the following conditions need to be taken into account:

- The panels need to absorb the wind load and convey this to the sub structure;
- The deflection of the panels due to this wind load should not exceed a two hundredth of the spanning distance (the distance between two fasteners on either direction);
- The maximum expansion under the influence of moisture and temperature changes is 1.5 mm/m, which needs to be considered with regard to joints.



## Screw fixing on a timber sub-frame

Screw fixing is the most traditional form of fixing and is likely to be the least expensive system to be considered as a Medite Tricoya façade rain screen system. Screws can pass through the cladding panel and into timber battens placed behind the cladding.

### SUB FRAME

Vertical timber battens, no smaller than 38 mm x 38 mm in section, should be used to support the cladding to the supporting wall or cladding structure. For the outer corner, a corner infill piece can be used to protect and finish the corner of the façade.

For the inner corner, a shadow gap of no less than 3 mm is normally used; with the rear battens masked using a flexible black or dark grey joint cover strip material.

### FASTENERS

Screws for face fixing should be made of stainless steel A2 or A4. The length of the screw should be at least 25 mm + panel thickness (+ any spacers). If the screw head diameter is at least 5 mm bigger than the hole diameter, it is assumed pull-through will not occur, because the pull-through resistance exceeds the withdrawal resistance. Holes for the fasteners should be pre-drilled, slightly over-sized ( $\geq 120\%$ ) compared to the shank diameter, to allow for panel and sub-frame expansion.

Screws should be positioned at least 25 mm from the edge of the panel and at least 75 mm from corners. The maximum edge distance for this type of fixing is 15 x panel thickness.

For further design guidance and pull out strengths, the fastener manufacturer should be contacted. For guidelines of the maximum fixing distances that follow from the maximum acceptable deflection of the panels, see the graphs on page 14.





### Fixing distances

The distances between the supports is crucial to the ultimate performance of the Medite Tricoya cladding panel.

As a general guideline, these graphs depict the maximum fixing distances for the different panel thicknesses, based on the maximum tolerable deflection of the panel (1/200 of the span).

Note that the maximum fixing distance of multiple span panels (three or more vertical fixings per panel), due to increased stiffness.

**The strength of the total system (spacing, number and type of fixing required due to wind loading) must at all times be checked by a licensed engineer.**

### Single span

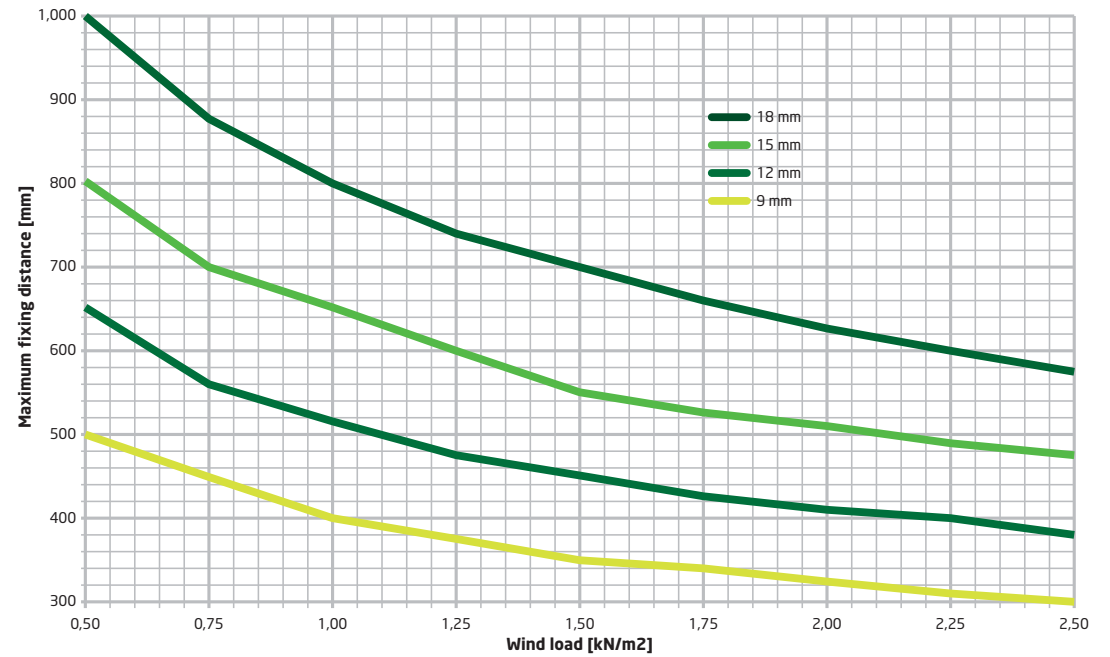

### Multiple span

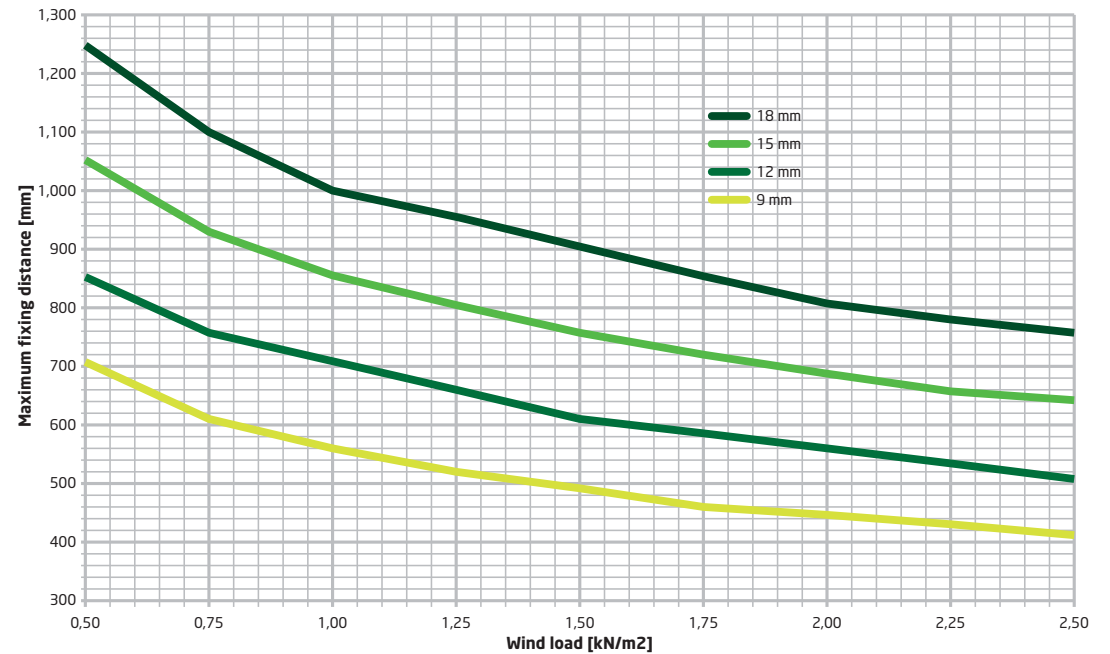



### Corner details

Corner solutions for Medite Tricoya as cladding can be detailed in numerous ways, both with and without incorporating profiles. When a board meets another construction part (or another board) a gap of at least 5 mm should be provided. Depending on the applicable national building code, to which you should refer, cavity barriers may be needed at corners.

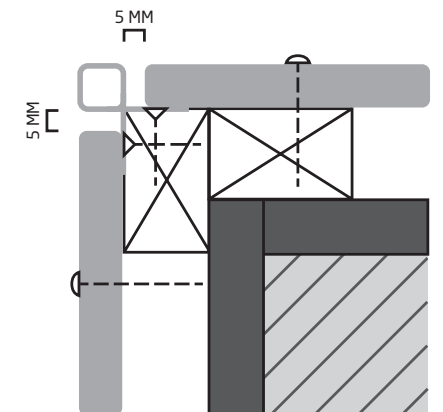
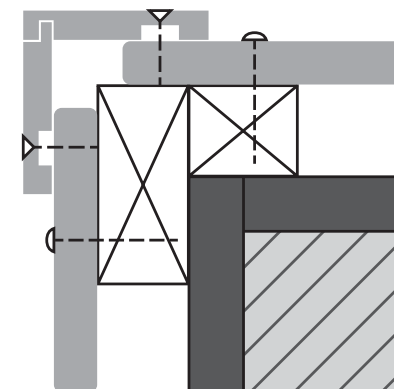
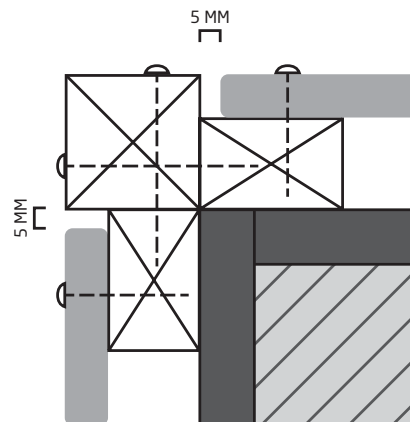
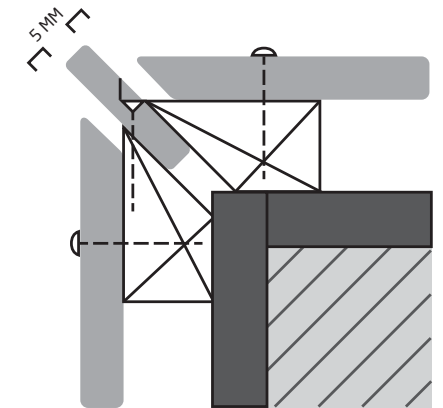
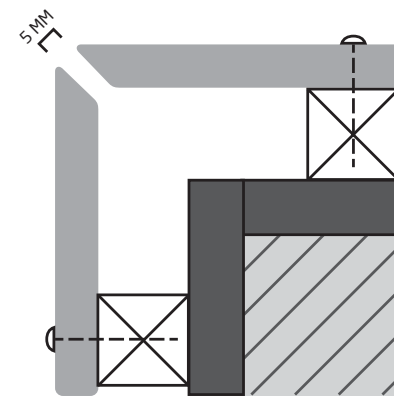
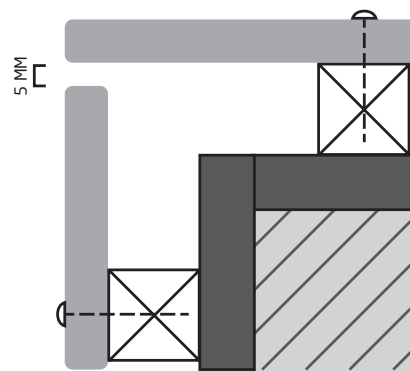
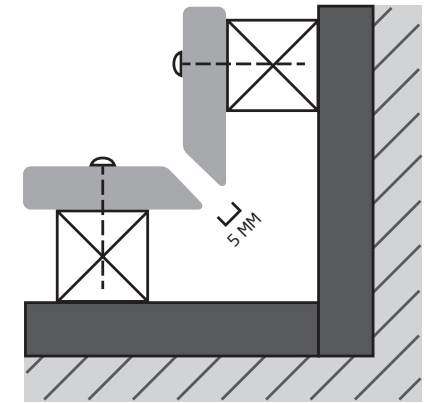
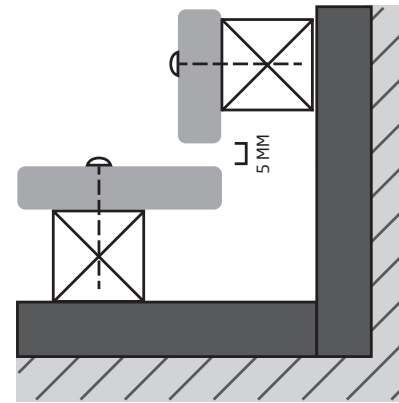

## Ventilation

Medite Tricoya is suitable for installation in a ventilated façade system.

This type of façade system is characterised by continuous ventilation behind the outer decorative layer, through the ventilation in- and outlets situated at the top and bottom of the façade (at least  $200 \text{ mm}^2$  per  $\text{m}^2$  cladding). This way, rain water and condensation behind the cladding is removed and the insulation behind the panels will not lose its effectiveness. It is recommended that the depth of the cavity behind the cladding should be at least 20 mm.

Note that the cavity depth as well as the minimum size of the ventilation in- and outlets must be in accordance with applicable building standards and regulations and that a water repellent, breathable membrane (UV resistant when joints are left open) is applied at the back of the cavity. An insect mesh might be required in ventilation in- and outlets and/or in case of open joints.

Although not a technical requirement for Medite Tricoya, we do recommend for aesthetic reasons that panels are positioned on the façade in such a way that no direct contact with the soil can take place. Furthermore, mounting panels in the splash zone, between ground level and a height of 200 to 250 mm, will lead to a reduction in service life of any coating (in case of a paved surface). Applying a gravel section below the cladding is recommended.

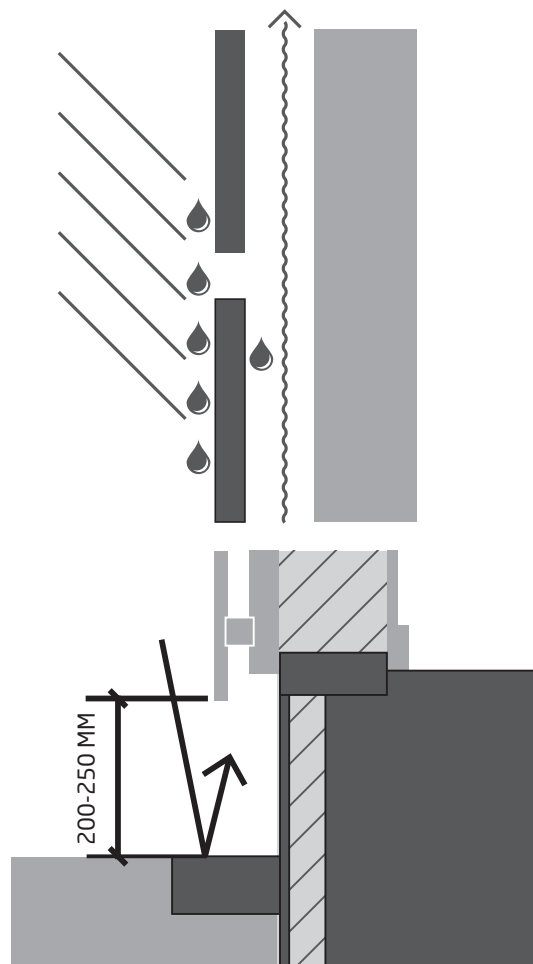

Note that panels should be fitted with spacers and not fitted flush to any masonry or brickwork.

## Joints

Considering the circumstances the Medite Tricoya is used in, the panels will not expand or shrink more than 1.5 mm/m in practice. However, the material will be mounted onto a sub-frame that shows a significant expansion and shrinkage due to changes in temperature and/or humidity, which needs to be taken into account.

Therefore, Medite Tricoya cladding panels need to be installed with (at least) a 5 mm free space around the edges. When the joint is left open, the sub frame supporting the panels should be protected (full width) by a suitable weather resistant joint tape in case of battens.



# OTHER EXTERIOR APPLICATIONS

## FASCIA AND SOFFITS

Medite Tricoya can be used for soffits or fascia finish for roof ends. Although different sub-frames are possible, the application onto battens (timber sub-frame) is the most usual. It is recommended to limit the maximum height of the boards as stated in the table below and to fix the board vertically at two places. The roof lining boards can be fastened visibly with wood screws, or they can be glued onto the sub-frame.

	PANEL THICKNESS	
	9mm	12mm
Board height ≤	250mm	400mm
Horizontal fixing distance ≤	500mm	500mm

It is also possible to fix the boards invisibly by using screws at the top of the board (which will be concealed by the roof trim) and fitting the tongued bottom edge into continuous (aluminium) U-shaped rails.

## CURVED PANELS

Because of its superior properties, Medite Tricoya can easily be curved and bent, according to the specifications opposite.

Curved boards can be fixed with the fasteners described in the chapter on cladding panels. In case of adhesive, the outer sides need to be fastened additionally with wood screws.

## SPANDREL PANELS

Due to its durability and enhanced dimensional stability, Medite Tricoya is suited for the application of walling between structural members e.g. a timber framed building. The panels can be as large as the numbers in the table below, provided the panels are fitted in a (sufficiently stiff) window frame on all edges. The size of the panel is limited in one direction only (either vertical or horizontal).

Panels with a length and width exceeding 1 metre should have an intermediate support installed. For the resulting two surfaces, the limits in the table below apply.

PANEL THICKNESS	MAX PANEL WIDTH
9mm	550mm
12mm	700mm
15mm	850mm
18mm	1,000mm

DIMENSIONS	6mm	9mm
Curve	2,440mm	2,440mm
Radius (R)	620mm	977mm
Angle (θ)	120mm	145
Chord	1,100mm	1,900mm
Level	900mm	750mm
Battens (c.t.c.)	300mm	400mm
Fixings edge (c.t.c.)	270mm	300mm
Fixings intermed. (c.t.c.)	300mm	300mm

## EXTERIOR CEILINGS

Medite Tricoya is also suited for use in horizontal applications like exterior ceilings (e.g. shopping centres, car ports and overhangs). The fixing systems described in the previous pages can be used:

- cladding boards
- screw fixing on a timber sub frame
- Invisible fixing with adhesive

The specific guidelines of the chosen fixing systems apply. We recommend limiting the support distance for cladding boards to 450 mm, and the fixing distance of cladding panels to 75% of those stated in the graphs on page 14 due to panel deflection by its own weight in a horizontal application.

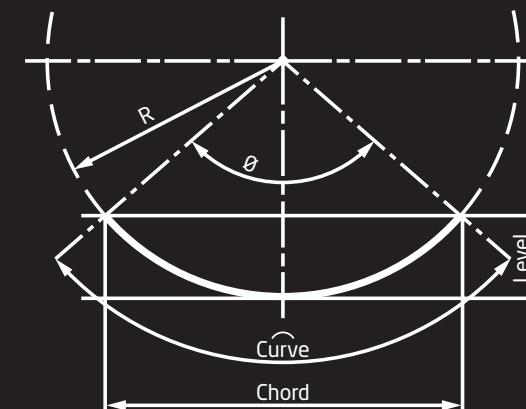

# COATINGS

There is no need to finish Medite Tricoya from a technical performance perspective, in respect of attributes such as decay resistance and dimensional stability. However, Medite Tricoya is susceptible to weathering in outdoor circumstances. Uncoated panels used outdoors will weather due to UV and biological processes that take place within the wood fibres and at its surface, which can be avoided by using a high quality resistant coating.

Medite Tricoya is all-natural and non-toxic so mould growth can occur if Medite Tricoya is left uncoated. Common mould growth can be avoided by using a suitable outdoor primer which addresses mould growth. Blue-stain can be avoided by using a high quality UV resistant coating. This also protects the wood from accidental staining.

The compatibility of Medite Tricoya with various coating systems compares well with wood in general and it may be finished with commonly used products.

Please note: coating formulations vary from supplier to supplier and, of course, processes vary depending on the application equipment used and end-product design. Despite our excellent record of compatibility, we highly recommend having your coating suppliers involved in the process as they have an in-depth knowledge of their products, application and how to determine the performance of the finished product.

For detailed information on certain coating suppliers, we refer to the download section of our website, please log onto [www.meditetricoya.com](http://www.meditetricoya.com).



## PREPARATION

- The moisture content of the Medite Tricoya to be coated should be dry (below 8% moisture content)
- The surface to be coated should be clean, dry and free from dust and grease
- It is recommended finishing the panels on all sides before mounting them, to prevent staining. Fire retardant treated panels must always be coated on both sides
- It is recommended to round off the corners with a radius of at least 3 mm
- For aesthetic reasons, it is recommended the edges of the panels to be treated with end-grain sealer (white or transparent), before applying the final coating
- When using a primer, a high quality product that contains resin-bleed blockers and fungicides is recommended.

## OPAQUE COATINGS (FILM FORMING)

The opaque and (semi-) translucent coating systems should be applied with a minimum dry film thickness that corresponds to the requirements of the end product and/or paint suppliers instructions.

## TRANSLUCENT COATINGS (NON-FILM FORMING)

As Medite Tricoya does not have a wood grain look but an MDF 'fibre' look, staining and oiling might not be the first colour treatment that comes to mind. However, using a semi-translucent coating gives a very distinctive almost wood like impression, especially with darker coloured semi-translucent coatings.

Further information on all coatings may be obtained directly from coating suppliers. A wide range of coatings will be suitable for use with Medite Tricoya. The table opposite contains industrially applied coating systems that are specifically tailored for and warranted with Medite Tricoya.

Note: These systems may vary from country to country, we therefore recommend that advice is sought directly from the coating company in your area

COATING MANUFACTURER	PRIMER	TOPCOAT	WARRANTY	SYSTEM
AkzoNobel	XP 650 Aqua PU Primer 256 2K	150–175 $\mu\text{m}$ (wet) in 1 or 2 layers: <ul style="list-style-type: none"> <li>• Akzo Nobel Winflex T25</li> <li>• Akzo Nobel Winflex T35</li> <li>• Akzo Nobel Winflex T3635</li> </ul>	up to 10 years	Opaque
Drywood		<ul style="list-style-type: none"> <li>• 2 layers Optifinish G40 / G70</li> <li>• 3 layers Optifinish TR SG / GL</li> </ul>	up to 15 years	Opaque
	2 layers Optiprimer G	finish front / edges at the construction site with e.g. Poseidon UV GL	up to 15 years	Opaque
		semi film forming: 3 layers (back side 2 layers) Woodstain VV	up to 15 years	Translucent
PPG	120 $\mu\text{m}$ (dry) in 2 layers PPG Wood Finishes 152Q0	<ul style="list-style-type: none"> <li>• 40 <math>\mu\text{m}</math> (dry) Sigma S2U (Semi-) Gloss</li> <li>• 50 <math>\mu\text{m}</math> (dry) PPG Wood Finishes 892 Q0</li> </ul>	up to 7 years <sup>1</sup>	Opaque
Remmers	Induline GW-310	1 or 2 layers Induline DW-603	up to 10 years	Opaque
	Induline GW-310	1 or 2 layers Induline LW-710	up to 10 years	Translucent
Sikkens	Rubbol WP 151 2K	150–175 $\mu\text{m}$ (wet) in 1 or 2 layers: <ul style="list-style-type: none"> <li>• Rubbol WF375</li> <li>• Rubbol WF387</li> <li>• Rubbol WF382</li> </ul>	up to 15 years <sup>2</sup>	Opaque
	Rubbol WM 260 1K	150–175 $\mu\text{m}$ (wet) in 1 or 2 layers: <ul style="list-style-type: none"> <li>• Rubbol WF375</li> <li>• Rubbol WF387</li> <li>• Rubbol WF382</li> </ul>	up to 15 years <sup>3</sup>	Opaque
Teknos	Teknoseal 4002	Aquatop 2600	up to 12 years	Opaque

1: warranty can be extended to 10 years with a planned over-coating with Sigma S2U Semi-Gloss in the 7th year.

2: warranty can be extended to 25 years with a planned over-coating with Rubbol XD Gloss in the 16th year.

3: warranty can be extended to 20 years with a planned over-coating with Rubbol XD Gloss in the 16th year.

## LAMINATES

The surface of Medite Tricoya can be covered or overlaid with wood, HPL, CPL and melamine papers. A number of industrial processors are successfully developing systems. For further information please contact Medite.

## MANUALLY APPLIED COATINGS

To achieve the best results, any coating on Medite Tricoya should best be applied industrially. However, if circumstances require, it is possible to apply a coating on Medite Tricoya manually. Apart from the general preparation (page 18) below are the recommendations for manually applied coatings.

### Priming

It is recommended to use an (industrially applied) primer to prevent uneven uptake of the finishing coat layers. The primer used should be a high-quality, low-odour, isolating, physically drying paint, that contains resin-bleed blockers and fungicides.

### Coating

To achieve a good covering, it is recommended to apply at least two layers. By lightly sanding the surface in between the layers, fibre roughening is eliminated. We strongly recommend adhering to the instructions of the paint manufacturer regarding the application method (brush, roller or spray) and the drying conditions (temperature and humidity).

### GLUING

To manufacture for example fixed corner profiles, Medite Tricoya can be glued together with D3 or D4 (EN204) class adhesives. In general Medite Tricoya can be glued using PU, RPF, or EPI wood adhesive systems.

## MORE INFORMATION

For more information please contact our sales office:

Ireland: +353 (0) 51 851 233  
Netherlands: +31 (0) 475 399 740  
UK: +44 (0) 1322 424900

Other brochures and information sheets on specific subjects like machining and handling, fasteners and specific coatings can also be found in the download section of [www.meditetricoya.com](http://www.meditetricoya.com)